

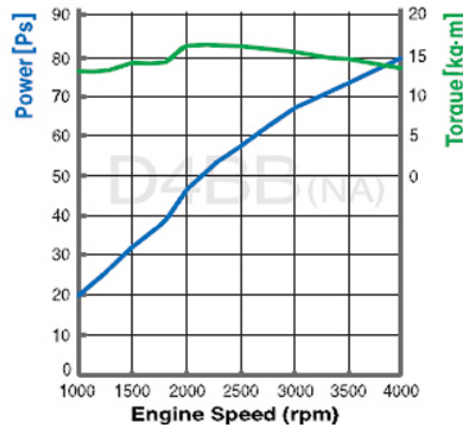

DIESEL FOR WATER PUMP



DESCRIPTION		D4BB(59KW/80PS/4,000RPM)
DISPLACEMENT(cc)		2,607
BORE X STROKE(mm)		91.1X100
MAX. POWER (ps/rpm)		80/4,000
MAX. TORQUE (kg.m/rpm)		17/2,200
DIMENSION (mm)	LENGTH	710
	WIDTH	673.4
	HEIGHT	641
WEIGHT IN DRY(kg)		200.8
CYCLE		4
NO. OF CYLINDER		4
CYLINDER ARRANGEMENT		IN-LINE
FIRING ORDER		1-3-4-2
COMPRESSION RATIO		22
ASPIRATION		NA
ALTERNATOR(V-A)		12-75
STARTER MOTOR(V-kw)		12-2.0
BSM(balance shaft module)		IN BLOCK
ETC(electronic throttle control)		Non
TIMING TRAIN		BELT

Technical data

Pump name

80x65 FS2JA 5

Customer	Date 01-February -2021	Company
Contact	Item no.	Issued by
Phone	Project	Phone
E-mail	Project ID	E-mail

Requested data

1	Pump type	End Suction Volute Pump	Fluid	Water, clean
2	Number of pumps / Reserve	1 / 0	Liquid temperature °C	20
3	Flow m ³ /h	0	Kin. viscosity mm ² /s	1
4	Head m	0	Vapour pressure bar	0.022
5	Geodetic head m	0	PH value	7
6	Inlet pressure (pin) bar	0.1	Density kg/dm ³	1
7	Available system NPSH	0	Solids Weight %	0
8	Ambient temperature °C	20		

Pump

9	Pump name	80x65 FS2JA 5	Frequency Hz	50
10	Design	End Suction Volute Pump	Installation type	bare shaft
11	Manufacturer	PTEI	Impeller Diameter	Max. mm 261
12	Speed 1/min	2900		Designed mm 261
13	No. of Stage	1		Min. mm 182
14	Connection Suction side	JIS 10K	Flow	Operating m ³ /h
15	Connection Discharge side	JIS 10K		Max- m ³ /h 93.9
16	Max Working Pressure bar	10		Min- m ³ /h 24
17	Shut-off head bar	9.51	Head	Operating m
18	Total weight kg	See the table of "Dimensions".		- (Qmax.) m 54.1
19	Shaft power kW			- (Qmin.) m 94.9
20			Max. Shaft Power at max. impeller kW	23.04
21	Required pump NPSH m		Efficiency %	

Materials

22	Casing	Cast iron	M.S.mating ring	Ceramic
23	Impeller	Bronze	M.S.seal ring	Carbon
24	Shaft	403 Stainless steel		
25	Casing ring	Bronze		
26	Ball bearing	.		
27	Mechanical seal	.		

Motor

28	Manufacturer	without motor	Insulation class	
29	Type	without motor 3	Phases	3~
30	Specific design	without motor / 50 Hz / Pole pairs 1	Frame size	
31	Rated power kW	-	Weight kg	0
32	Number of poles	2	Electric voltage V	0
33	Speed 1/min	-	Electric current A	0
34	Degree of protection	--		
35				

Remarks

--

Performance curve Pump name 80x65 FS2JA 5

Customer	Date 01-February -2021	Company
Contact	Item no.	Issued by
Phone	Project	Phone
E-mail	Project ID	E-mail

Requested data

1	Flow	m ³ /h	0
2	Head	m	0
3	Geodetic head	m	0

Pump

Operating Flow	m ³ /h	Frequency	Hz	50
Operating Head	m	Number of poles	2	
Impeller Diameter	Designed mm	261	Speed	1/min

Test standard: ISO 9906:2012 - Grade3B

Water, clean [100%] ; 20°C; 0.9983kg/dm³; 1.005mm²/s

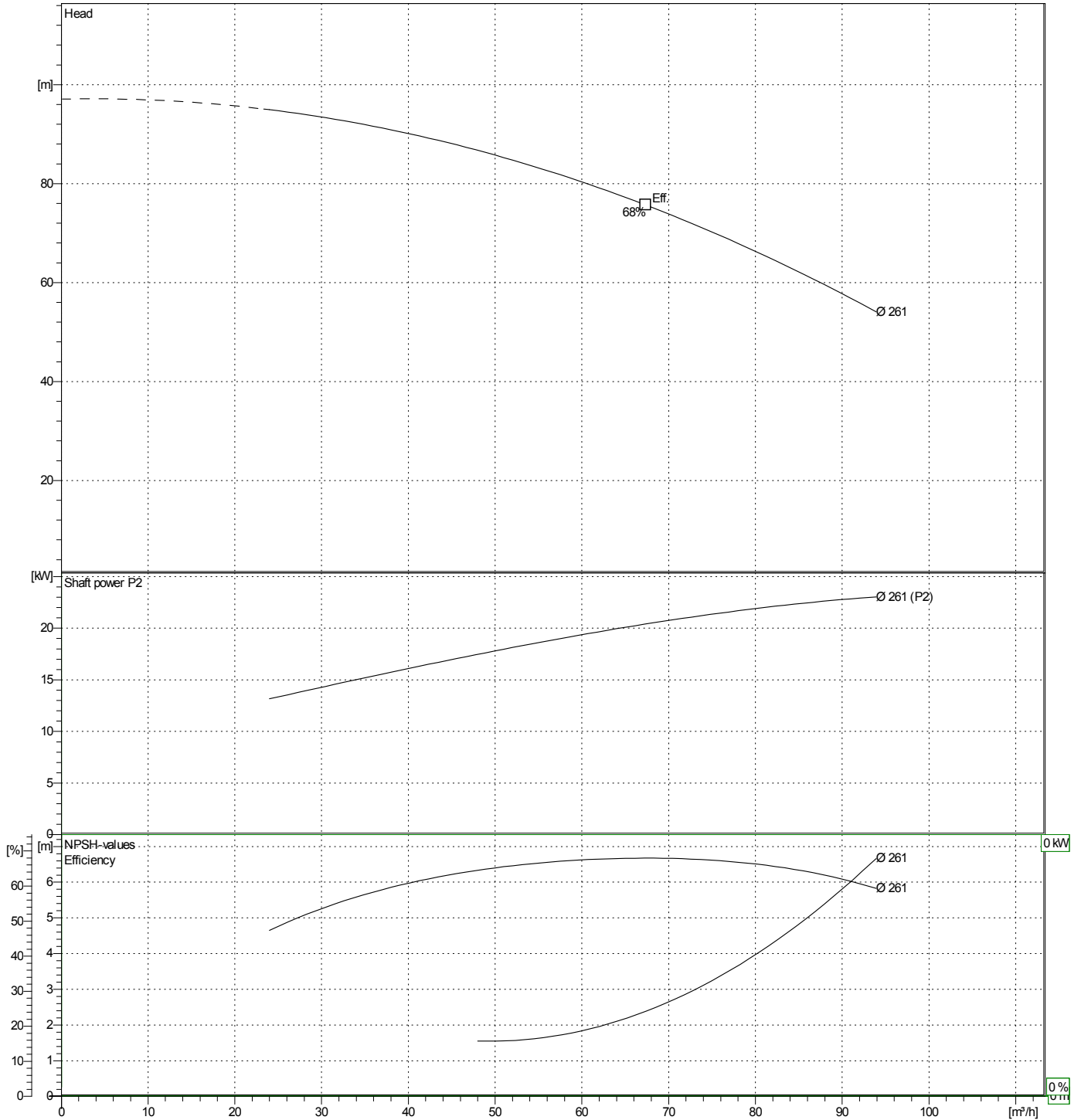

Dimensions

Pump name 80x65 FS2JA 5

Customer	Date 01-February -2021	Company
Contact	Item no.	Issued by
Phone	Project	Phone
E-mail	Project ID	E-mail

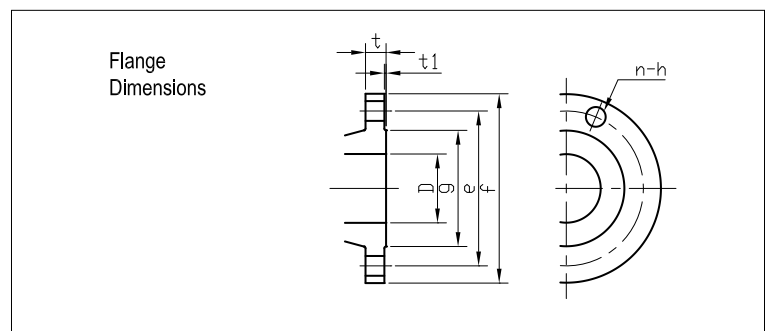
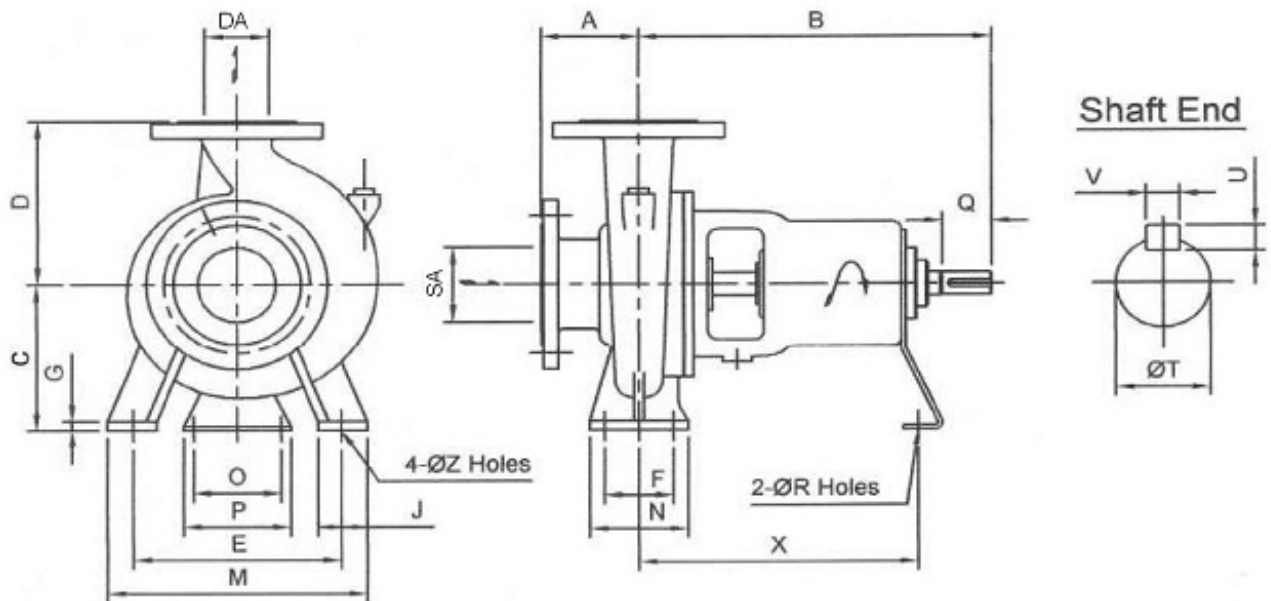

Total weight : 60 kg

Pump dimensions				mm		Suction side		mm		Discharge side		mm	
A	100	Q	80	D	80	D	65						
B	360	R	17	e	150	e	140						
C	180	SA	80	f	185	f	175						
D	225	T	32	g	126	g	116						
DA	65	U	8	h	19	h	19						
E	250	V	10	n Num	8	n Num	4						
F	95	X	285	t	22	t	22						
G	14	Z	15	t1	2	t1	2						
J	65												
M	320												
N	125												
O	110												
P	150												

(1/2) Construction

Pump name 80x65 FS2JA 5

Customer	Date 01-February -2021	Company
Contact	Item no.	Issued by
Phone	Project	Phone
E-mail	Project ID	E-mail

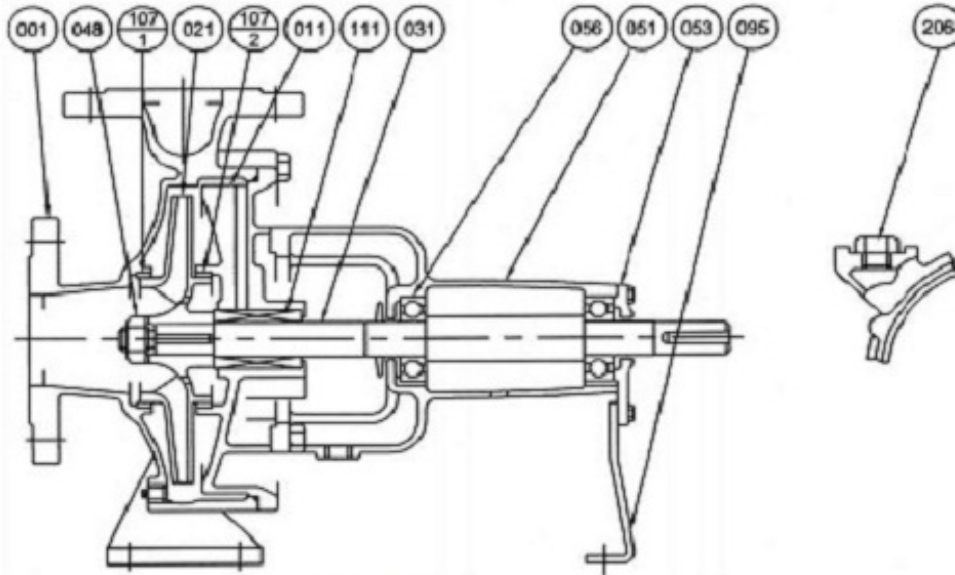

Model FH

50x40 FSHA; 65x50 FSHA, FSJA;
80x65 FSGA, FSHA, FSJA, FSKA;
100x80 FSGA, FSHA, FSJA;
125x100 FSKA

Model EA

100x65 FSKA; 100x80 FSGCA, FSHCA;
125x100 FSJCA, FSLA;
150x100 FSKA, FSNA;
150x125 FSHA, FSJA, FSKA, FSLA;
200x150 FSHA, FSJA, FSKA, FSLA, FSNA;
250x200 FSLA, FSNA

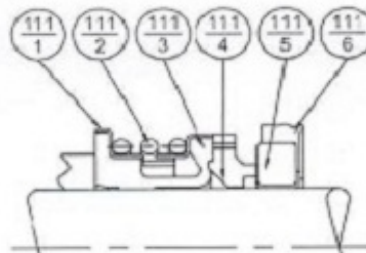
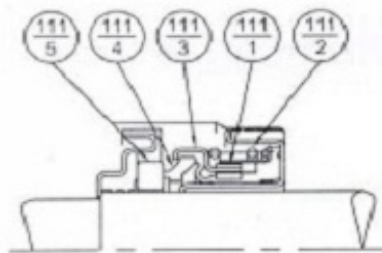

111-5	Mating Ring	Ceramic	1
111-4	Seal Ring	Carbon	
111-3	Friction Ring	NBR	
111-2	Coil Spring	Stainless Steel	
111-1	Spring Holder	Stainless Steel	
No.	Part Name	Material	Qty

111-6	Cup Gasket	NBR	1
111-5	Mating Ring	Ceramic	
111-4	Seal Ring	Carbon	
111-3	Bellows	NBR	
111-2	Spring	Stainless Steel	
111-1	Spring Holder	Stainless Steel	
No.	Part Name	Material	Qty

207	Plug	Steel	1
111	Mechanical Seal	-	
107-2	Casing Ring	Bronze	
107-1	Casing Ring	Bronze	1
095	Stay	Steel	
056	Ball Bearing	-	2
053	Bearing Cover	Cast Iron	1
051	Bearing Housing		
048	Impeller Nut	Brass	1
031	Shaft	Stainless Steel	
021	Impeller	Bronze	
011	Casing Cover	Cast Iron	
001	Casing		
No.	Part Name	Material	Qty

(2/2) Construction

Pump name 80x65 FS2JA 5

Customer	Date 01-February -2021	Company
Contact	Item no.	Issued by
Phone	Project	Phone
E-mail	Project ID	E-mail

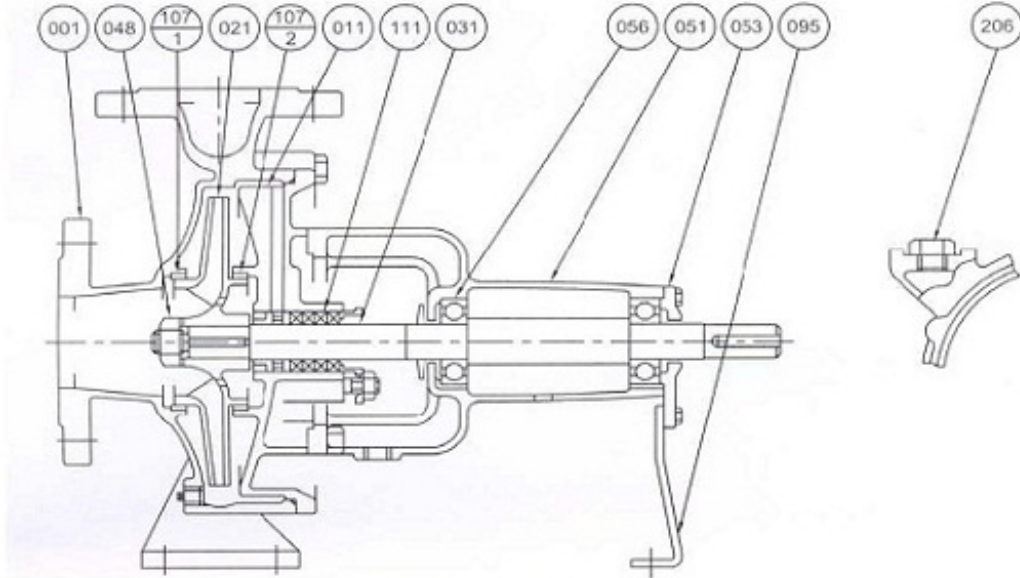

With Lantern Ring

50x40 FSHA; 65x50 FSHA, FSJA;
80x65 FSGA, FSHA;
100x80 FSGA; 125x100 FSLA;
150x100 FSKA, FSNA;
150x125 FSKA, FSLA;
200x150 FSJA, FSLA, FSNA;
250x200 FSLA, FSNA

Without Lantern Ring

80x65 FSJA, FSKA;
100x65 FSKA;
100x80 FSHA, FSJA, FSGCA, FSHCA;
125x100 FSJCA, FSKA;
150x125 FSHA, FSJA;
200x150 FSHA, FSKA;

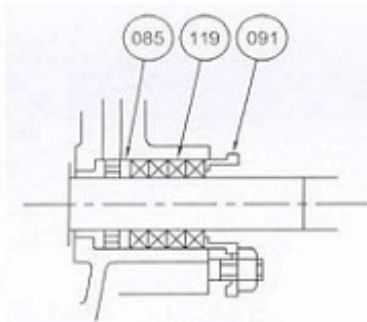

119	Gland Packing	Non-Asbestos	4 or 5
091	Gland	Bronze	1
085	Lantern Ring		
No.	Part Name	Material	Qty

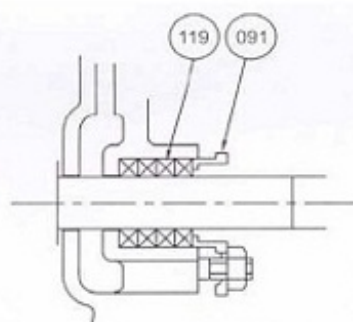

119	Gland Packing	Non-Asbestos	4 or 5
091	Gland	Bronze	1
No.	Part Name	Material	Qty

207	Plug	Steel	1
111	Gland Packing	Non-Asbestos	4 or 5
107-2	Casing Ring	Bronze	1
107-1	Casing Ring		
095	Stay	Steel	1
056	Ball Bearing	-	2
053	Bearing Cover	Cast Iron	1
051	Bearing Housing		
048	Impeller Nut	Brass	
031	Shaft	Stainless Steel	
021	Impeller	Bronze	
011	Casing Cover	Cast Iron	
001	Casing		
No.	Part Name	Material	Qty