



daedong



4B243LWS

General Specification

Type	4Cyl, 4Cycle, Liquid cooled Diesel
Combustion system	Indirect Injection
Rated Power	36.5kW (49HP) / 2600rpm
Max. Torque	157N.m / 1700rpm
Fuel Consumption	268 g/kWh under
Bore X Stroke	87mm X 102.4mm
Displacement	2.435 L (148.6in ³)
Idle min/max. rpm	1000 / 2800rpm
Aspiration	Naturally Aspirated
Engine Oil capacity	9 L
Governor type	Mechanical
Cooling fan	400mm Puller type
Alternator	12V, 50Amp
Power Take Off	Flywheel [190(7-1/2)] Flywheelhousing (SAE #4) Fuelcamshaft spline (25x18x1.25)
Emission Regulation	EPA Tier 4 Interim EEC Stage 3A Korea Tier 3

Features



Image shown may not be actual engine

Approximate Dimensions and Weight

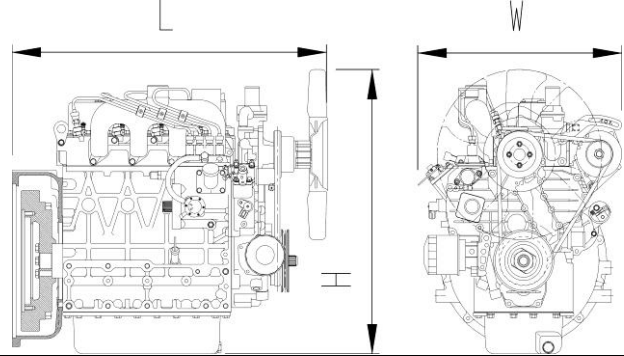

Length(L)	mm	766
	in	30.2
Width(W)	mm	495
	in	19.5
Height(H)	mm	630
	in	24.8
Dry weight	kg	207
	lb	455

4B243LW FULL LOAD CURVE

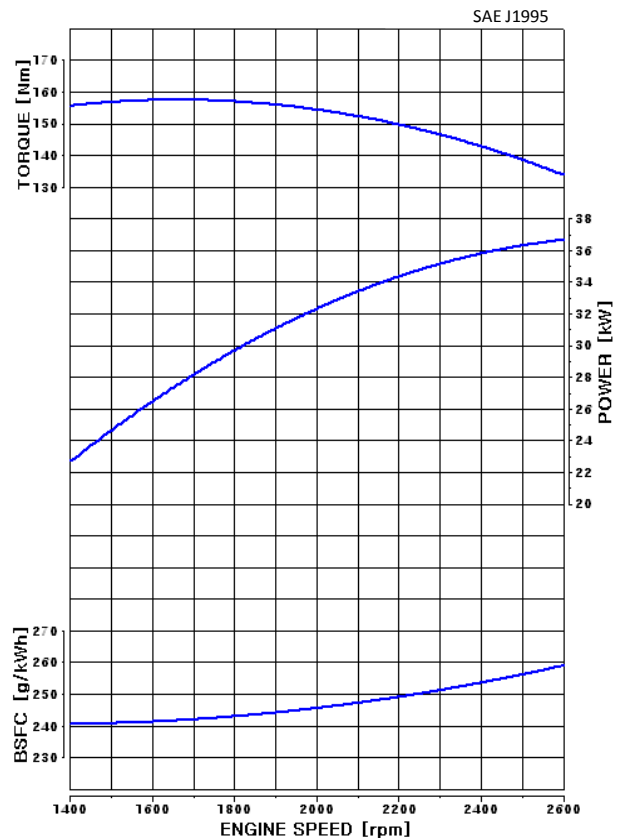

Pump Performance Curve

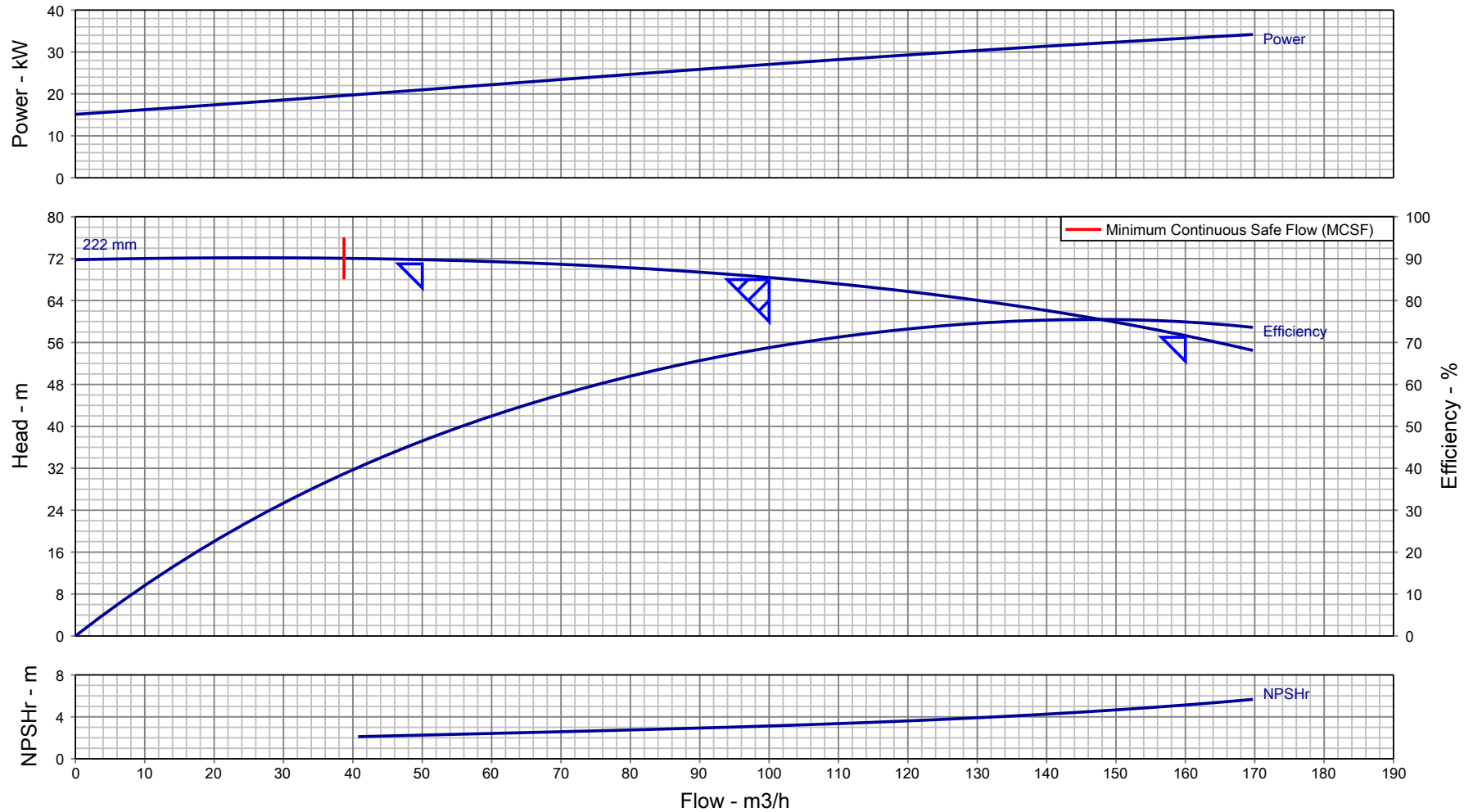

Customer :	Pump Size/ Stages : DB 80/26/ 1	Flow, rated : 100.0 m ³ /h
Customer enquiry :	Speed, rated : 2955 rpm	Differential Head : 68.00 m
Project : Default	Based on curve number : HD10220A0 Rev 0	Fluid density rated : 0.998 kg/dm ³
Quote number : 312657	Viscosity : 1.00 cSt	Efficiency : 68.78 %
Item number : 001	Cq/Ch/Ce/Cn [HI2010] : 1.00 / 1.00 / 1.00 / 1.00	Power, rated : 27.05 kW
Quantity : 1	Minimum recommended driver rating : 37.00 kW / 49.62 hp	NPSH required : 3.13 m
Date last saved : 08 Dec 2020 8:40 AM	Performance testing standard : ISO 9906 / ANSI-HI 14.6 Gr 2B	Liquid Type/ Application : Water

Notes: 1. Performance at shut off condition is approximate. 2. Rated impeller diameter is approximate. 3. Only duty point is guaranteed as per testing standard.



Enriching Lives

Pump Performance Datasheet			
General			
Customer	:	Quote number	: 312657
Customer Enquiry No.	:	Pump model	: DB 80/26
Project	: Default	Stages	: 1
End user	: -	Based on curve number	: HD10220A0 Rev 0
Tag number	: 001	Date last updated	: 08 Dec 2020 8:40 AM
Service	: -	Quantity of pumps	: 1
Operating Conditions		Liquid	
Flow, rated	: 100.0 m3/h	Liquid handled	: Water
Suction pressure, rated / max	: 0.00 bar.g / 0.00 bar.g	Additional liquid description	: Fresh Water
Discharge pressure, rated	: 6.70 bar.g	Temperature, max	: 20.00 deg C
Head, rated (requested)	: 68.00 m	Solids diameter, max	: 0.00 mm
NPSH available, rated	: Value not specified	Solids in suspension by volume	: 0.00 %
Frequency	: 50 Hz	Specific gravity, rated / max	: 0.998 / 0.998 kg/dm3
Performance		Viscosity, Rated / Max.	: 1.00 cSt / -
Pump speed, rated	: 2955 rpm	Driver & Power Data	
Impeller Dia, Rated (Approx.)	: 222 mm	Driver sizing specification	: Maximum Power
Impeller diameter, maximum	: 264 mm	Margin over specification	: 0.00 %
Impeller diameter, minimum	: 205 mm	Power, rated	: 27.05 kW
Efficiency at duty point	: 68.78 %	-	: -
NPSH required / margin required	: 3.13 m / 0.50 m	-	: -
MCSF	: 38.72 m3/h	Driver Rating	: 37KW
Cq/Ch/Ce: [-]	: 1.00 / 1.00 / 1.00	Pressure Data	
Water eq. duties (Qw/Hw/Ew)	: 100.0 m3/h / 68.00 m / 68.78 %	Maximum working pressure	: 7.06 bar.g
Suction / Delivery nozzle size	: 100 mm / 80.00 mm	Maximum allowable working pressure	: 16.00 bar.g
Noise level	: 90 dB	Maximum allowable suction pressure	: 1.96 bar.g
Vibration level (RMS)	: 5.1 mm/s	Hydrostatic test pressure	: 18.34 bar.g
Test standard	: ISO 9906 / ANSI-HI 14.6 Gr 2B	Construction	
Starting condition	: Closed Delivery Valve	Basic construction	: End Suction Pump-OH1
Material		Impeller type	: Enclosed
MOC Code	: 16MOC	Selection status	: Acceptable
Material (Casing / Impeller / Shaft)	: CI IS210:FG260 (012) / CI IS210:FG260 (012) / ST ST ASTM A276-410 ANLD (253)	Rec. Pipe Size (Suc / Del)	: 150 mm / 125 mm
-	: -		

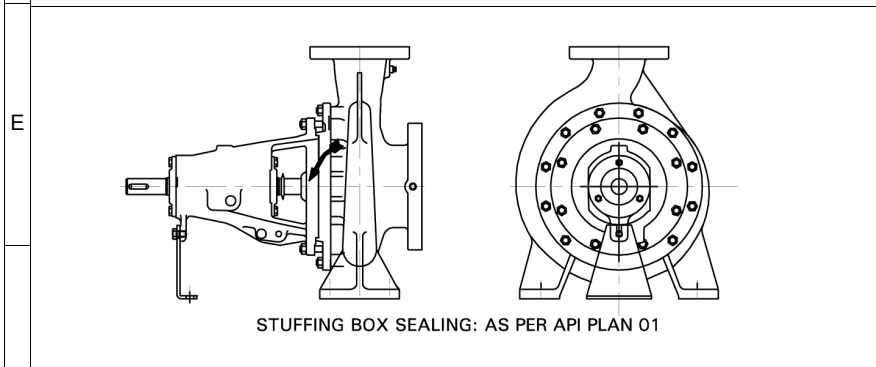
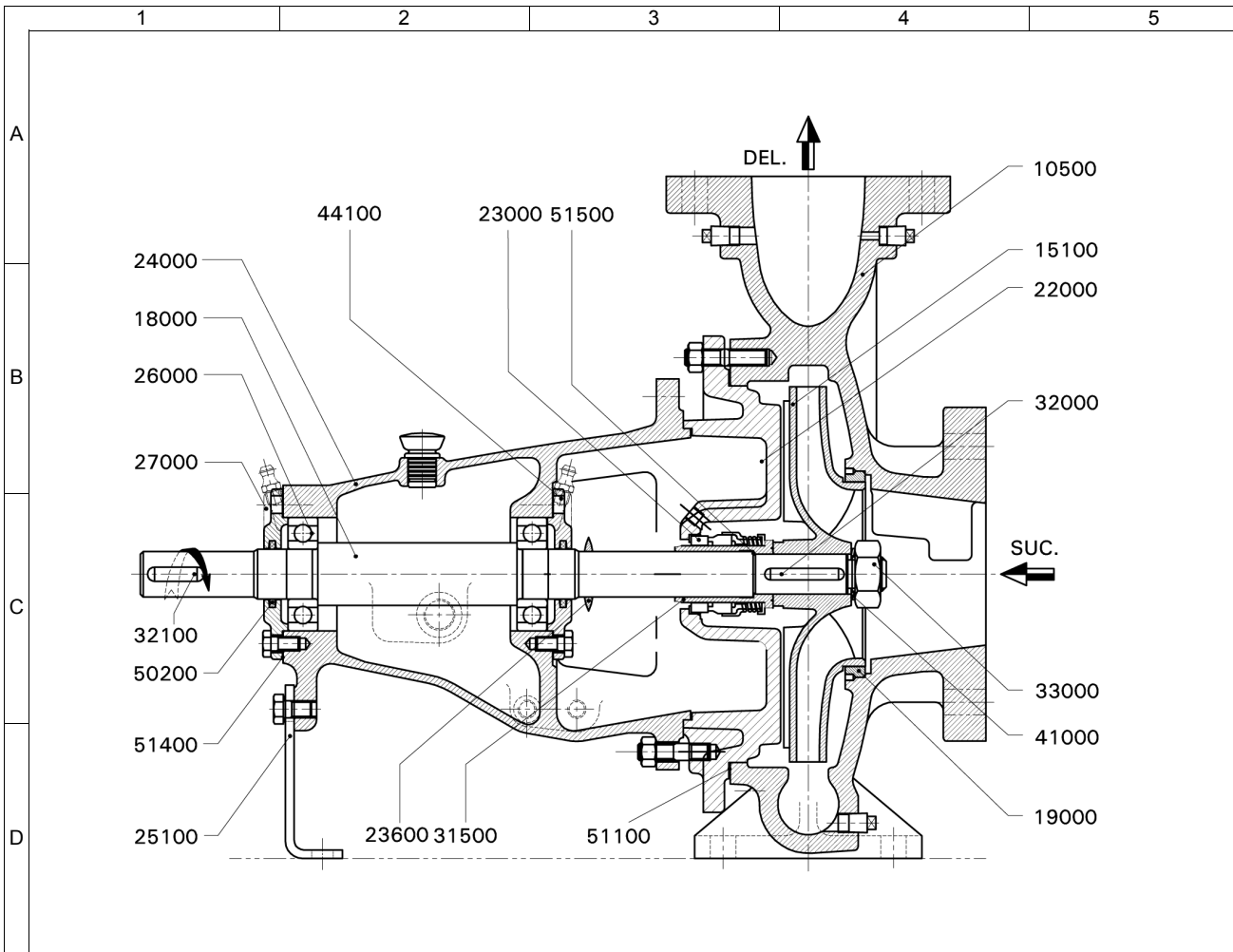

STUFFING BOX SEALING: AS PER API PLAN 01

PUMP FLANGES (FF)

- NOTES:**
- " * " INDICATES RECOMMENDED SPARES.
 - FASTENERS IN LIQUID CONTACT ARE IN CS

IMPORTANT: THIS DRAWING IS THE PROPERTY OF Kirloskar Brothers Limited. AND MUST NOT BE USED OR COPIED WITHOUT THEIR PRIOR AUTHORITY IN WRITING.



Enriching Lives

PART NO.	PART DESCRIPTION	MAT. CODE	MOC DESCRIPTION
10500	PUMP CASING	012	CI IS210:FG260
15100*	IMPELLER	012	CI IS210:FG260
18000*	PUMP SHAFT	253	ST ST ASTM A276-410 ANLD
19000*	WEAR RING - SUCTION SIDE	012	CI IS210:FG260
22000	CASING COVER	012	CI IS210:FG260
23000*	MECHANICAL SEAL	998	DIN SEAL
23600*	LIQUID DEFELCTOR	370	NATURAL RUB ASTM D2000AA-70SHORE/7MPa
24000	BEARING HOUSING	012	CI IS210:FG260
25100	SUPPORT FOOT	042	MS IS:5986-Fe410WA (OLD-IS:1079)
26000*	DEEP GROOVE BALL BEARING	000	STEEL
27000	BEARING COVER DE & NDE	012	CI IS 210-FG 260
31500*	SHAFT SLEEVE - MECHANICALSEAL	565	ST ST ASTMA276-410(210/250BHN)-ANLD
32000*	KEY FOR IMPELLER	253	ST ST ASTM A276-410 ANLD
32100	KEY FOR COUPLING	053	CS IS1570:40C8 HOT RLD
33000*	IMPELLER NUT	664	AUS ST ASTMA194/194M-8M-UNS S31600 (NUT)
41000*	LOCK WASHER-IMPELLER NUT	054	SPRING ST IS:4072-80C6
44100	GREASE NIPPLE	444	CS IS:1367 Part3 CL4.6 CDP
50200*	FELT RING	375	FELT
51100*	GASKET-CASING COVER	702	NON ASBESTOS FERROLITE NAM37 OR EQ
51400*	GASKET-BEARING COVER	702	NON ASBESTOS FERROLITE NAM37 OR EQ
51500*	GASKET-SHAFT SLEEVE	702	NON ASBESTOS FERROLITE NAM37 OR EQ

PUMP	DB 80/26	MOC	16
ENQUIRY NO./DATE	/	QUANTITY	1
PO. NO./DATE	-	TAG NO.	001
QUOTATION NO.	0	DATE.	-
O/A. NO.	-	MISI.	-
CUSTOMER	-		
END USER	-		
PROJECT	Default		
CONSULTANT	-		
SERVICE	-		

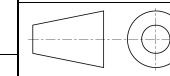

Kirloskar Brothers Limited
KIRLOS KARVADI - 416308, DIST.- SANGLI (INDIA)

CROSS SECTIONAL DRAWING

DRAWING NO. **TC02-1**

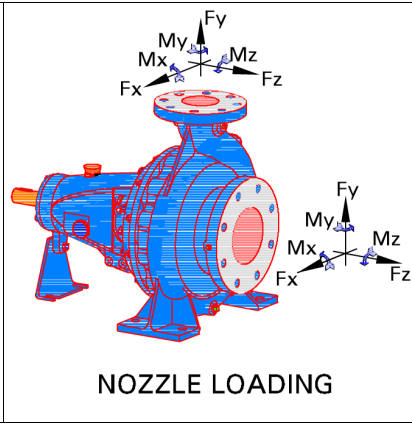
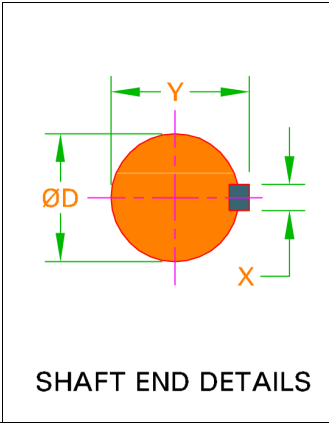
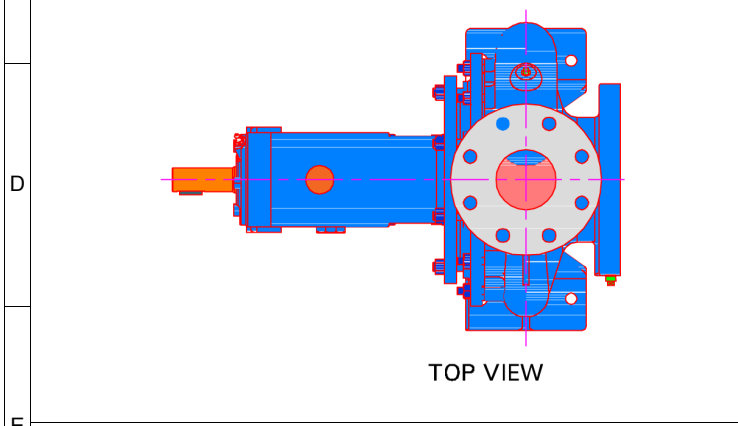
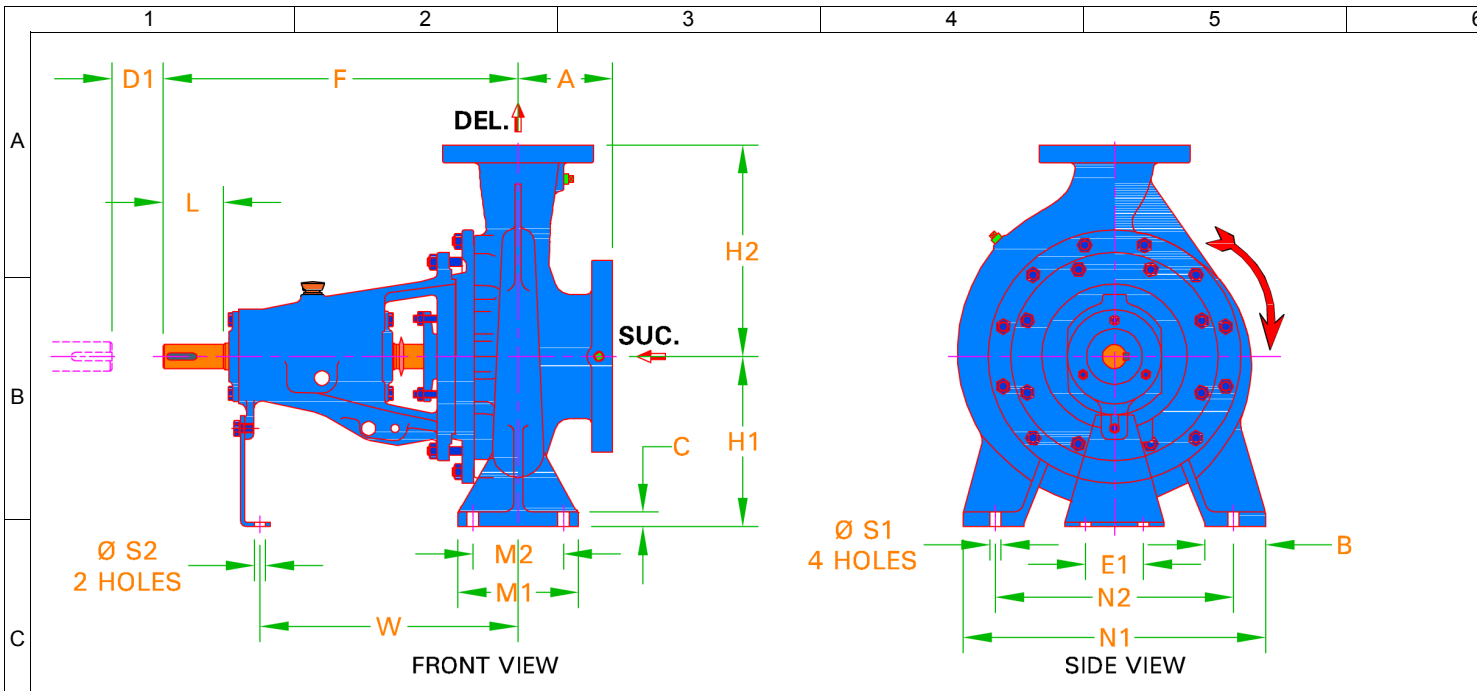

PUMP DUTIES			
CAPACITY	100.0 m ³ /h	EFFICIENCY	68.78 %
TOTAL HEAD	68.00 m	PUMP INPUT	27.05 kW
DENSITY	0.998 kg/dm ³	NPSHR	3.13 m

FLANGE DRILLING STANDARD AND DETAILS					
SUCTION	BS EN1092 PN16 FF		DELIVERY	BS EN1092 PN16	
	NOM. SIZE	RF DIA.	P.C.D.	NO OF HOLES	HOLE DIA.
SUCTION	100 mm	N.A.	180 mm	8	18.0
DELIVERY	80.00 mm	N.A.	160 mm	8	18.0

ALLOWABLE NOZZLE LOADING						
	FORCES			MOMENTS		
	Fx	Fy	Fz	Mx	My	Mz
SUCTION	91.00 kgf	227.0 kgf	182.0 kgf	1,353 N.m	677 N.m	677 N.m
DELIVERY	68.00 kgf	170.0 kgf	136.0 kgf	1,020 N.m	510 N.m	510 N.m

TAPPING DETAILS	
DESCRIPTION	SIZE / TYPE
Suction Gauge	1/4"BSP
Delivery Gauge	1/4"BSP
Casing Drain	3/8"BSP
Casing Vent	NA
Bearing Cooling in / out	NA
Pad Cooling in / out	NA
Priming in	NA
Base Drain	NA

DIRECTION OF ROTATION FROM DE		CLOCKWISE	
PUMP	DB 80/26	PUMP WT.	91.00
REC. DRIVER RATING	37KW	GD*2	0.03 kg
ENQ. NO./DATE	/	RATED SPEED	2955R
PO. NO./DATE	-	QUANTITY	1
QUOTATION NO.	0	TAG NO.	001
O/A NO.	-	DATE	-
CUSTOMER	-	MISI	-
END USER	-		
PROJECT	Default		
CONSULTANT	-		
SERVICE	-		

NOTES:
 • ALL DIMENSIONS ARE IN mm
 • DIM 'D1' INDICATES THE DISTANCE REQUIRED TO REMOVE BACK PULL OUT ASSEMBLY.

IMPORTANT: THIS DRAWING IS THE PROPERTY OF Kirloskar Brothers Limited AND MUST NOT BE USED OR COPIED WITHOUT THEIR AUTHORITY IN WRITING.

A	F	H1	H2	B	C	M1	M2	N1	N2	S1	E1	S2	W	-	D
125	470	200	280	80.00	16.00	160	120	400	315	18.00	110	14.00	267	-	32.00
X	Y	L	D1	-	-	-	-	-	-	-	-	-	-	-	-
10.00	35.00	80.00	140	-	-	-	-	-	-	-	-	-	-	-	-
-	-	-	-	-	-	-	-	-	-	-	-	-	-	-	-
-	-	-	-	-	-	-	-	-	-	-	-	-	-	-	-

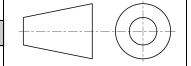

Kirloskar Brothers Limited
 KIRLOS KARVADI - 416308, DIST. - SANGLI (INDIA)

PUMP OUTLINE DRAWING