

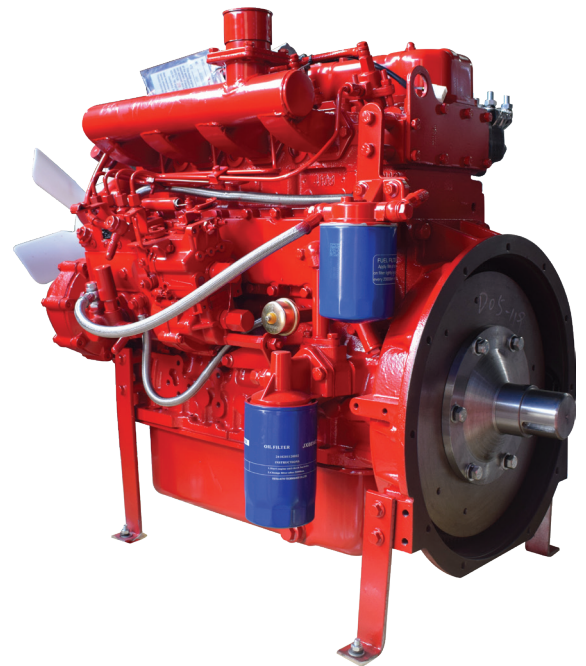

ANHUI QUANCHAI ENGINE CO., LTD

Model		Quanchai 4105ZQ
Displacement (cc)		4090
Bore x Stroke (mm)		105x118
Aspiration		Turbocharged
Rated Power (Kw/Hp/rpm)		90/120/2920
Maximun Torque (N.m/rpm)		310/1800
Dimensions (mm)	Length	922
	Width	640
	Height	1160
Weight in dry (kg)		385
Engine type (stroke)		4
No. of cylinder		4
Cylinder arrangment		In-line
Firing Order		1-3-4-2
<p>Note: The engine is new 100%, manufactured by Quanchai Corporation, China, have CO, CQ.</p>		

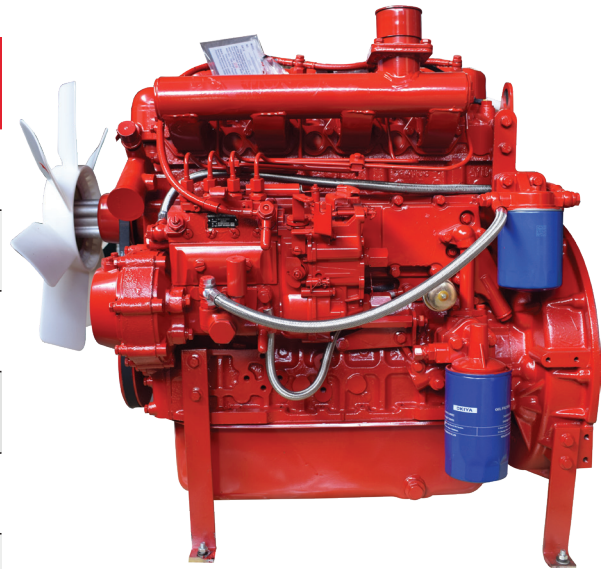

Authorised Dealer:
SONG HAN TRADING IMPORT EXPORT CO., LTD
 40 Binh Phu St., Tam Phu Ward, Thu Duc Dist, HCMC, Vietnam
Tel: +84-028-3729-6513
Email: info@songhan-motor.com.vn
Website: www.songhan-motor.com.vn

Pump Performance Curve

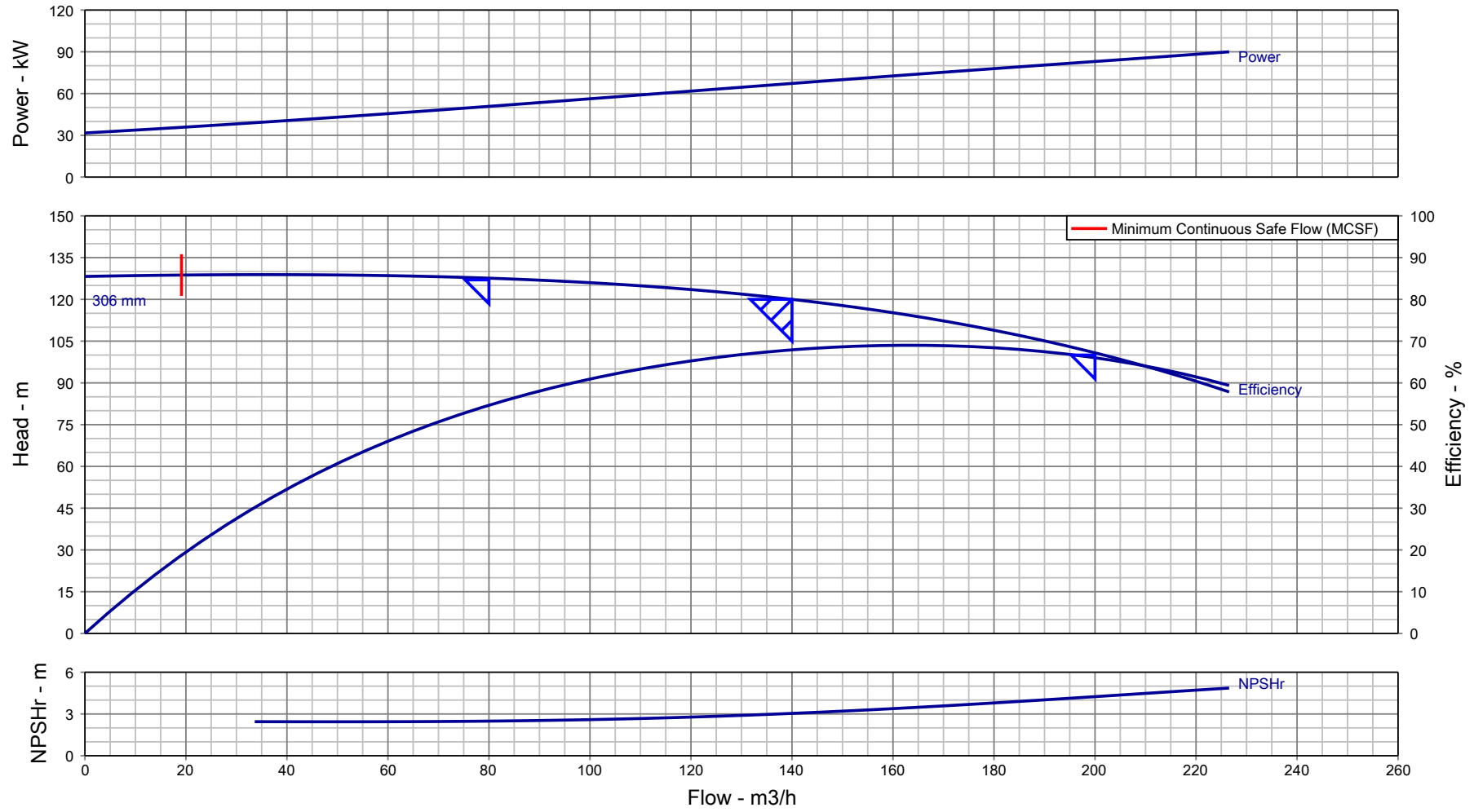

Customer :	Pump Size/ Stages : CPHM 80/32/ 1	Flow, rated : 140.0 m ³ /h
Customer enquiry :	Speed, rated : 2970 rpm	Differential Head : 120.0 m
Project : Default	Based on curve number : HD13723KA0 Rev 0	Fluid density rated : 0.998 kg/dm ³
Quote number : 312657	Viscosity : 1.00 cSt	Efficiency : 67.92 %
Item number : 001	Cq/Ch/Ce/Cn [HI2010] : 1.00 / 1.00 / 1.00 / 1.00	Power, rated : 67.27 kW
Quantity : 1	Minimum recommended driver rating : 90.00 kW / 121 hp	NPSH required : 3.04 m
Date last saved : 09 Oct 2020 11:56 AM	Performance testing standard : ISO 9906 / ANSI-HI 14.6 Gr 2B	Liquid Type/ Application : Water

Notes: 1. Performance at shut off condition is approximate. 2. Rated impeller diameter is approximate. 3. Only duty point is guaranteed as per testing standard.



Enriching Lives

Pump Performance Datasheet			
General			
Customer	:	Quote number	: 312657
Customer Enquiry No.	:	Pump model	: CPHM 80/32
Project	: Default	Stages	: 1
End user	: -	Based on curve number	: HD13723KA0 Rev 0
Tag number	: 001	Date last updated	: 09 Oct 2020 11:56 AM
Service	: -	Quantity of pumps	: 1
Operating Conditions		Liquid	
Flow, rated	: 140.0 m3/h	Liquid handled	: Water
Suction pressure, rated / max	: 0.00 bar.g / 0.00 bar.g	Additional liquid description	: Fresh Water
Discharge pressure, rated	: 11.75 bar.g	Temperature, max	: 20.00 deg C
Head, rated (requested)	: 120.0 m	Solids diameter, max	: 0.00 mm
NPSH available, rated	: Value not specified	Solids in suspension by volume	: 0.00 %
Frequency	: 50 Hz	Specific gravity, rated / max	: 0.998 / 0.998 kg/dm3
Performance		Viscosity, Rated / Max.	: 1.00 cSt / -
Pump speed, rated	: 2970 rpm	Driver & Power Data	
Impeller Dia, Rated (Approx.)	: 306 mm	Driver sizing specification	: Maximum Power
Impeller diameter, maximum	: 329 mm	Margin over specification	: 0.00 %
Impeller diameter, minimum	: 255 mm	Power, rated	: 67.27 kW
Efficiency at duty point	: 67.92 %	-	: -
NPSH required / margin required	: 3.04 m / 0.50 m	-	: -
MCSF	: 19.13 m3/h	Driver Rating	: 90KW
Cq/Ch/Ce: [-]	: 1.00 / 1.00 / 1.00	Pressure Data	
Water eq. duties (Qw/Hw/Ew)	: 140.0 m3/h / 120.0 m / 67.92 %	Maximum working pressure	: 12.62 bar.g
Suction / Delivery nozzle size	: 125 mm / 80.00 mm	Maximum allowable working pressure	: 16.00 bar.g
Noise level	: 85 dB	Maximum allowable suction pressure	: 2.00 bar.g
Vibration level (RMS)	: 5.1 mm/s	Hydrostatic test pressure	: 20.59 bar.g
Test standard	: ISO 9906 / ANSI-HI 14.6 Gr 2B	Construction	
Starting condition	: Closed Delivery Valve	Basic construction	: End Suction Pump-OH1
Material		Impeller type	: Enclosed
MOC Code	: 01MOC	Selection status	: Near Miss
Material (Casing / Impeller / Shaft)	: CI IS210:FG260 (012) / CI IS210:FG260 (012) / CS IS1570:40C8 HOT RLD (053)	Rec. Pipe Size (Suc / Del)	: 200 mm / 150 mm
-	: -		



Enriching Lives

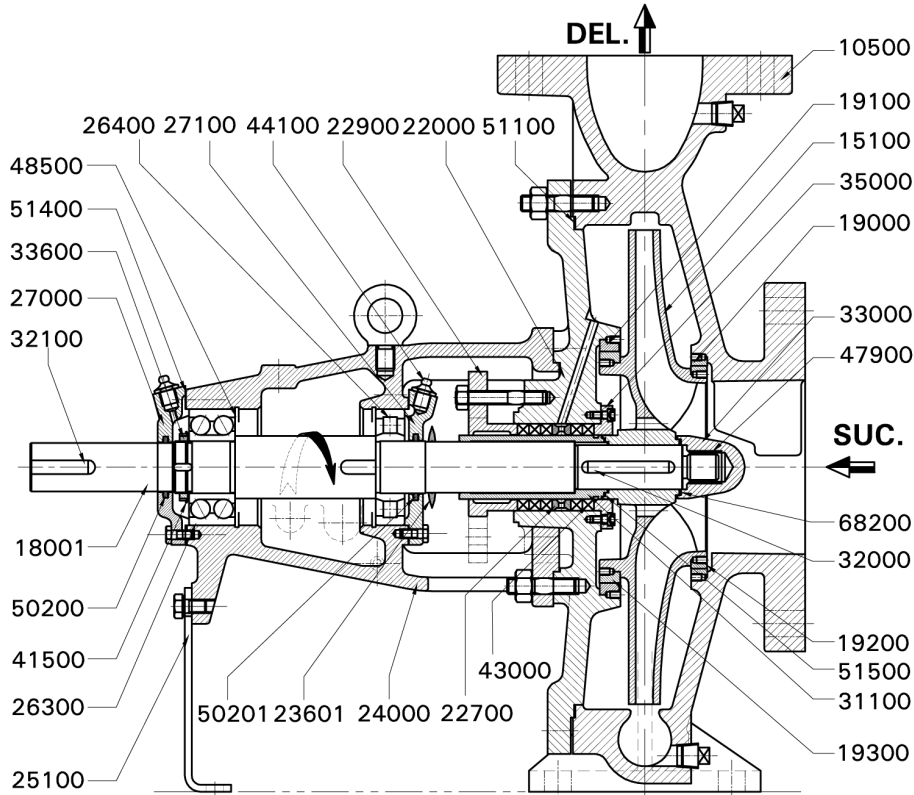

PART NO.	PART DESCRIPTION	MAT. CODE	MOC DESCRIPTION
10500	PUMP CASING	012	CI IS210:FG260
15100*	ENCLOSED IMPELLER	012	CI IS210:FG260
18001*	PUMP SHAFT	053	CS IS1570:40C8 HOT RLD
19000*	CSG. WEAR RING - SUC. SIDE	012	CI IS210:FG260
19100*	CSG. WEAR RING - DEL. SIDE	012	CI IS210:FG260
19200*	IMP. WEAR RING - SUC. SIDE	012	CI IS210:FG260
19300*	IMP. WEAR RING - DEL. SIDE	012	CI IS210:FG260
22000	CASING COVER	012	CI IS210:FG260
22700*	LANTERN RING	364	NYLON
22900	SPLIT GLAND	012	CI IS210:FG260
23601	LIQUID DEFLECTOR	370	NATURAL RUB ASTM2000AA-70SHORE/7MPa
24000	BEARING HOUSING	012	CI IS 210-FG 260
25100	SUPPORT FOOT	042	MS IS:5986-Fe410WA (OLD-IS:1079)
26300*	ANGULAR CONTACT BEARING	000	STEEL
26400*	CYLINDRICAL ROLLER BEARING	000	STEEL
27000	BEARING COVER DE	012	CI IS 210-FG 260
27100	BEARING COVER NDE	012	CI IS 210-FG 260
31100*	SHAFT SLEEVE	556	ST ST ASTM A276-410(300BHN)-ANLD
32000*	KEY FOR IMPELLER	053	CS IS1570:40C8 HOT RLD
32100	KEY FOR COUPLING	053	CS IS1570:40C8 HOT RLD
33000	IMPELLER NUT	253	ST ST ASTM A276-410 ANLD
33600*	BEARING LOCK NUT	052	CS IS1570:20C8 HOT RLD
35000*	STUFFING BOX BUSH	012	CI IS 210-FG 260
41500*	LOCK WASHER -BRG.LOCK NUT	050	CS IS1570:10C4 HOT RLD
43000*	GLAND PACKING	810	PTFE BRAIDED WITH GRAPHITE (PTFE-NONAS)
44100	GREASE NIPPLE	444	CS IS:1367 Part3 CL4.6 CDP
47900*	HELICOIL SCREW LOCK INSERT	250	ST ST ASTM A276-304 ANLD
48500*	INTERNAL CIRCLIP	054	SPRING ST IS:4072-80C6
50200*	FELT RING -DE SIDE	375	FELT
50201*	FELT RING -NDE SIDE	375	FELT
51100*	GASKET : CASING COVER	702	NON ASBESTOS FERROLITE NAM37 OR EQ
51400*	GASKET : BEARING COVER	702	NON ASBESTOS FERROLITE NAM37 OR EQ
51500*	GASKET : SH. SLEEVE & IMP.	702	NON ASBESTOS FERROLITE NAM37 OR EQ
68200*	GASKET : IMP. & IMP. NUT	702	NON ASBESTOS FERROLITE NAM37 OR EQ

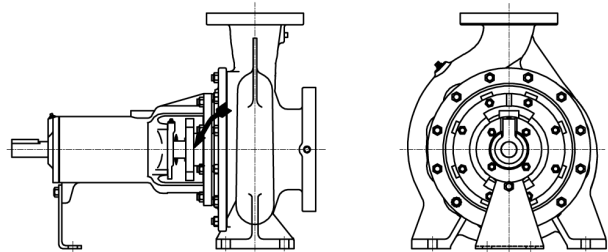

STUFFING BOX SEALING: SELF INTERNAL

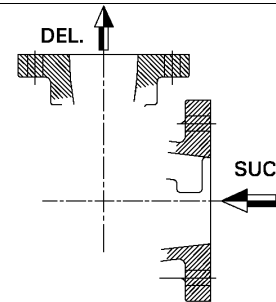

PUMP FLANGES (FF)

- NOTES:**
- * * * INDICATES RECOMMENDED SPARES.
 - FASTENERS IN LIQUID CONTACT ARE IN CS

IMPORTANT: THIS DRAWING IS THE PROPERTY OF Kirloskar Brothers Limited. AND MUST NOT BE USED OR COPIED WITHOUT THEIR PRIOR AUTHORITY IN WRITING.

PUMP	CPHM 80/32	MOC	01
ENQUIRY NO./DATE	/	QUANTITY	1
PO. NO./DATE	-	TAG NO.	001
QUOTATION NO.	0	DATE.	-
O/A. NO.	-	MISI.	-
CUSTOMER	-		
END USER	-		
PROJECT	Default		
CONSULTANT	-		
SERVICE	-		

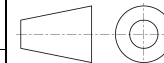

Kirloskar Brothers Limited
KIRLOSKARVADI - 416308, DIST.- SANGLI (INDIA)

CROSS SECTIONAL DRAWING

DRAWING NO. **TC78-1**

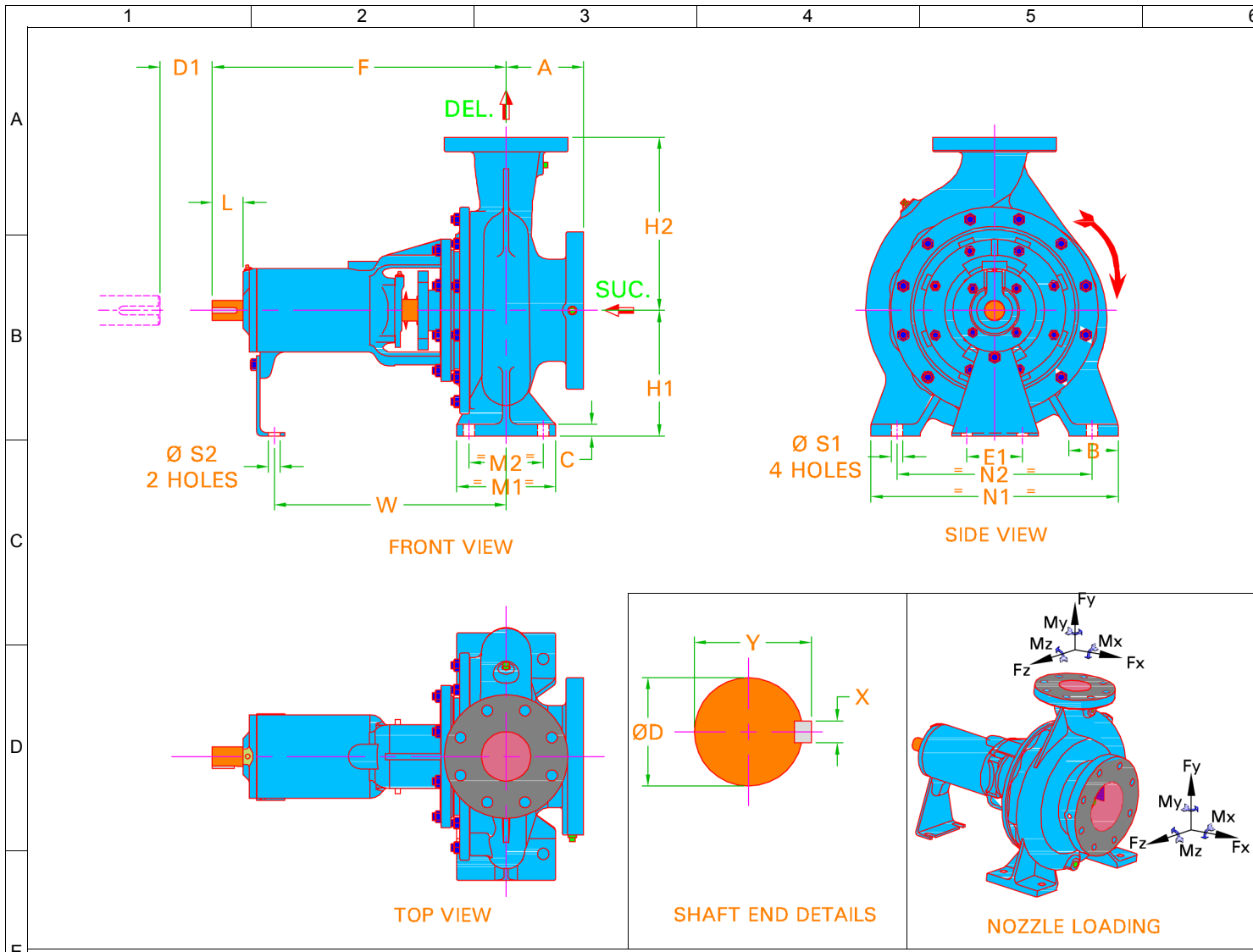

Enriching Lives

PUMP DUTIES

CAPACITY	140.0 m3/h	EFFICIENCY	67.92 %
TOTAL HEAD	120.0 m	PUMP INPUT	67.27 kW
DENSITY	0.998 kg/dm3	NPSHR	3.04 m

FLANGE DRILLING STANDARD AND DETAILS

SUCTION	BS EN1092 PN16 FF	DELIVERY	BS EN1092 PN16
NOM. SIZE	RF DIA.	P.C.D.	NO OF HOLES
SUCTION	125 mm	N.A.	210 mm
DELIVERY	80.00 mm	N.A.	160 mm

ALLOWABLE NOZZLE LOADING

	FORCES			MOMENTS	
	Fx	Fy	Fz	Mx	My
SUCTION	200.0 kgf	260.0 kgf	170.0 kgf	1,079 N.m	686 N.m
DELIVERY	200.0 kgf	260.0 kgf	170.0 kgf	1,079 N.m	686 N.m

TAPPING DETAILS

DESCRIPTION	SIZE / TYPE
Suction Gauge	1/2"BSP
Delivery Gauge	1/2"BSP
Casing Drain	1/2"BSP
Casing Vent	NA
Bearing Cooling in / out	NA
Pad Cooling in / out	NA
Priming in	NA
Base Drain	1 BSP

- NOTES:**
- ALL DIMENSIONS ARE IN mm
 - DIM 'D1' INDICATES THE DISTANCE REQUIRED TO REMOVE BACK PULL OUT ASSEMBLY.

IMPORTANT: THIS DRAWING IS THE PROPERTY OF Kirloskar Brothers Limited AND MUST NOT BE USED OR COPIED WITHOUT THEIR AUTHORITY IN WRITING.

A	F	H1	H2	B	C	M1	M2	N1	N2	S1	E1	S2	W	-	D
125	530	250	315	80.00	16.00	160	120	400	315	18.00	110	15.00	370	-	42.00
X	Y	L	D1	-	-	-	-	-	-	-	-	-	-	-	-
12.00	45.00	110	140	-	-	-	-	-	-	-	-	-	-	-	-
-	-	-	-	-	-	-	-	-	-	-	-	-	-	-	-
-	-	-	-	-	-	-	-	-	-	-	-	-	-	-	-

DIRECTION OF ROTATION FROM DE CLOCKWISE

PUMP	CPHM 80/32	PUMP WT.	120.0
REC. DRIVER RATING	90KW	GD*2	0.49 kg
ENQ. NO./DATE	/	RATED SPEED	2970R
PO. NO./DATE	-	QUANTITY	1
QUOTATION NO.	0	TAG NO.	001
O/A NO.	-	DATE	-
CUSTOMER	-	MISI	-
END USER	-		
PROJECT	Default		
CONSULTANT	-		
SERVICE	-		

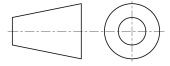

Kirloskar Brothers Limited
KIRLOSKARVADI - 416308, DIST. - SANGLI (INDIA)

PUMP OUTLINE DRAWING

DRAWING NO. TL78-1-