

DIESEL ENGINE

KDP SERIES FOR FIRE PUMP

Model: 4KDP-60

Prime power 60.0KW(80.0HP)/3000 rpm
Standby Power 66.0KW(88.0HP)/3000 rpm

Engine Specifications

In-Line, 4 stroke, water-cooled, Natural Aspiration
 Combustion type Direct injection
 Cylinders - Bore × stroke 4 - 102 × 118 mm
 Displacement 3857 cc
 Firing order 1 – 3 – 4 – 2
 Compression ratio 18 : 1
 Dry weight Approx. 335 kg
 Dimension(LxWxH) 885 × 640 × 810 mm
 Rotation Anti-clockwise
 Flywheel / Housing SAE # 10 / # 3

Fuel System

Injection pump Direct Injection type
 Governor Mechanicaltype
 Feed pump Mechanicaltype
 Injection nozzle Multi-hole type/ 0.255 mm
 Opening pressure 20+0.5MPa
 Fuel filter Single Stage, Paper

Fuel Consumption

Prime power at 3000rpm 17.0 liters/h
 Standby Power at 3000rpm 18.7 liters/h

Cooling System

Cooling method Fresh water forced type
 Water pump Centrifugal, Belt driven
 Max. water Temp 95 degree C.
 Cooling Fan Blade 7EA - Ø 450 mm

Lubrication System

Lub. Oil Pan Capacity 7.5 liters
 Max. allowable Oil Temp 110 degree C.
 Min. 294 kPa
 Max. 490 kPa
 Oil pressure

Intake & Exhaust System

Max air restriction Clean 2 kPa / Dirty 5 kPa
 Exhaust back Max 6 kPa

Engineering Data

Combustion Air 2.92m³/min
 Exhaust Gas 6.76m³/min

Electric System

Charging generator 13.5 V × 65 A
 Starting motor 12 V × 3.7 kW
 Battery 12 V × 120 Ah

Conversion Table

PS = kW × 1.3596 in. = mm × 0.0394
 psi = kg/cm² × 14.2233
 HP= PS × 0.98635

Pump Performance Curve

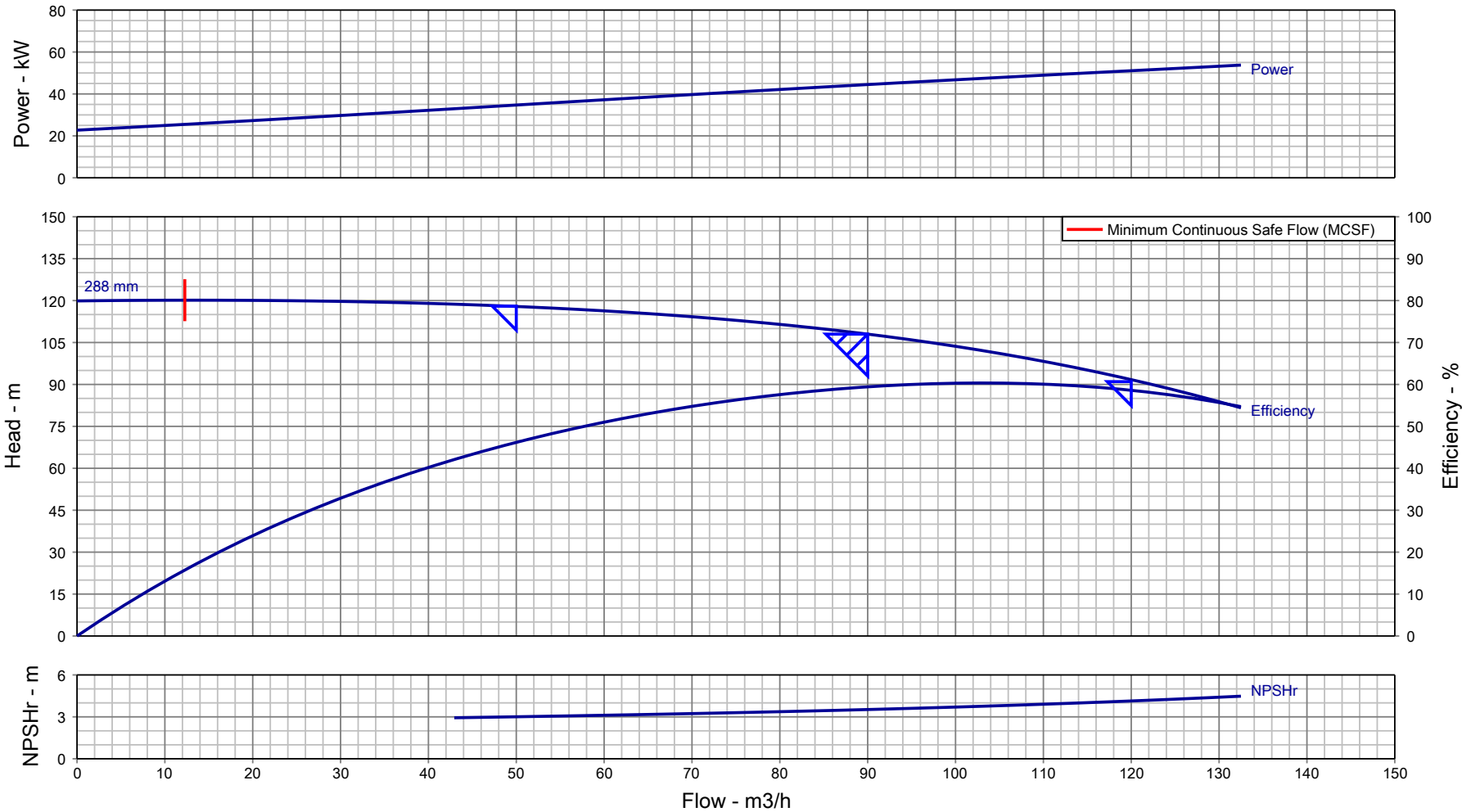

Customer :	Pump Size/ Stages : CPHM 65/32_2900RPM/ 1	Flow, rated : 90.00 m ³ /h
Customer enquiry :	Speed, rated : 2965 rpm	Differential Head : 108.0 m
Project : Default	Based on curve number : HD13740KA0 Rev 0	Fluid density rated : 0.998 kg/dm ³
Quote number : 312657	Viscosity : 1.00 cSt	Efficiency : 59.43 %
Item number : 001	Cq/Ch/Ce/Cn [HI2010] : 1.00 / 1.00 / 1.00 / 1.00	Power, rated : 44.48 kW
Quantity : 1	Minimum recommended driver rating : 55.00 kW / 73.76 hp	NPSH required : 3.52 m
Date last saved : 09 Oct 2020 8:58 AM	Performance testing standard : ISO 9906 / ANSI-HI 14.6 Gr 2B	Liquid Type/ Application : Water

Notes: 1. Performance at shut off condition is approximate. 2. Rated impeller diameter is approximate. 3. Only duty point is guaranteed as per testing standard.



Enriching Lives

Pump Performance Datasheet

General			
Customer	:	Quote number	: 312657
Customer Enquiry No.	:	Pump model	: CPHM 65/32_2900RPM
Project	: Default	Stages	: 1
End user	: -	Based on curve number	: HD13740KA0 Rev 0
Tag number	: 001	Date last updated	: 09 Oct 2020 8:58 AM
Service	: -	Quantity of pumps	: 1
Operating Conditions		Liquid	
Flow, rated	: 90.00 m3/h	Liquid handled	: Water
Suction pressure, rated / max	: 0.00 bar.g / 0.00 bar.g	Additional liquid description	: Fresh Water
Discharge pressure, rated	: 10.57 bar.g	Temperature, max	: 20.00 deg C
Head, rated (requested)	: 108.0 m	Solids diameter, max	: 0.00 mm
NPSH available, rated	: Value not specified	Solids in suspension by volume	: 0.00 %
Frequency	: 50 Hz	Specific gravity, rated / max	: 0.998 / 0.998 kg/dm3
		Viscosity, Rated / Max.	: 1.00 cSt / -
Performance		Driver & Power Data	
Pump speed, rated	: 2965 rpm	Driver sizing specification	: Maximum Power
Impeller Dia, Rated (Approx.)	: 288 mm	Margin over specification	: 0.00 %
Impeller diameter, maximum	: 329 mm	Power, rated	: 44.48 kW
Impeller diameter, minimum	: 255 mm	-	: -
Efficiency at duty point	: 59.43 %	-	: -
NPSH required / margin required	: 3.52 m / 0.50 m	Driver Rating	: 55KW
MCSF	: 12.27 m3/h		
Cq/Ch/Ce: [-]	: 1.00 / 1.00 / 1.00		
Water eq. duties (Qw/Hw/Ew)	: 90.00 m3/h / 108.0 m / 59.43 %		
Suction / Delivery nozzle size	: 100 mm / 65.00 mm		
Noise level	: 85 dB		
Vibration level (RMS)	: 5.1 mm/s		
Test standard	: ISO 9906 / ANSI-HI 14.6 Gr 2B		
Starting condition	: Closed Delivery Valve		
Material		Pressure Data	
MOC Code	: 01MOC	Maximum working pressure	: 11.76 bar.g
Material (Casing / Impeller / Shaft)	: CI IS210:FG260 (012) / CI IS210:FG260 (012) / CS IS1570:40C8 HOT RLD (053)	Maximum allowable working pressure	: 16.00 bar.g
-	: -	Maximum allowable suction pressure	: 2.00 bar.g
		Hydrostatic test pressure	: 20.59 bar.g
		Construction	
		Basic construction	: End Suction Pump-OH1
		Impeller type	: Enclosed
		Selection status	: Near Miss
		Rec. Pipe Size (Suc / Del)	: 150 mm / 125 mm



Enriching Lives

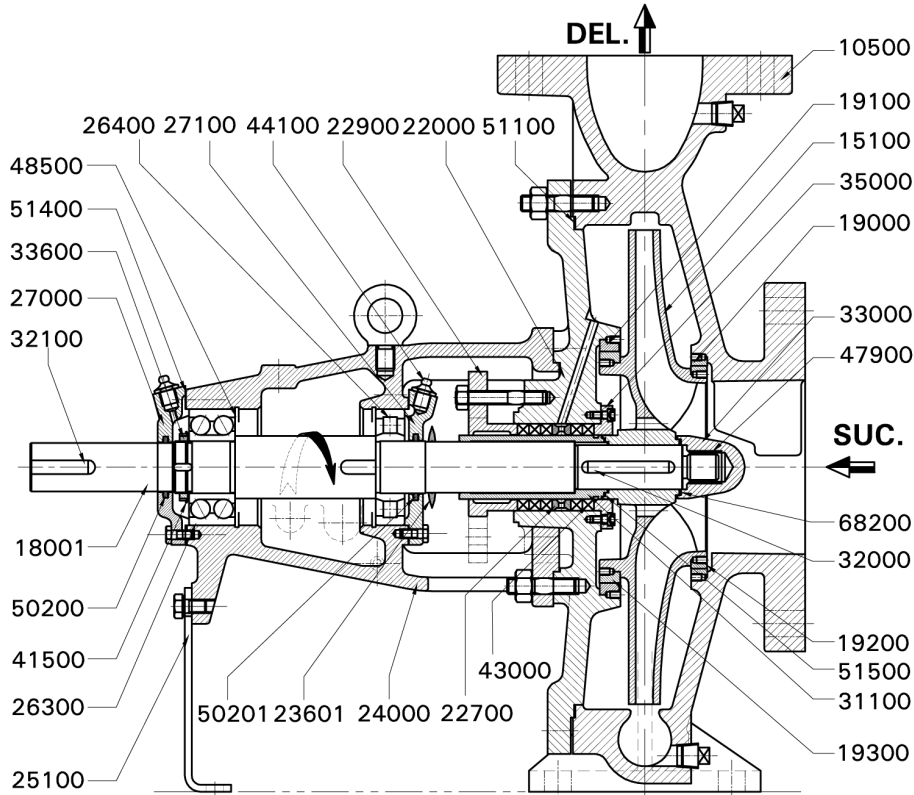

PART NO.	PART DESCRIPTION	MAT. CODE	MOC DESCRIPTION
10500	PUMP CASING	012	CI IS210:FG260
15100*	ENCLOSED IMPELLER	012	CI IS210:FG260
18001*	PUMP SHAFT	053	CS IS1570:40C8 HOT RLD
19000*	CSG. WEAR RING - SUC. SIDE	012	CI IS210:FG260
19100*	CSG. WEAR RING - DEL. SIDE	012	CI IS210:FG260
19200*	IMP. WEAR RING - SUC. SIDE	012	CI IS210:FG260
19300*	IMP. WEAR RING - DEL. SIDE	012	CI IS210:FG260
22000	CASING COVER	012	CI IS210:FG260
22700*	LANTERN RING	364	NYLON
22900	SPLIT GLAND	012	CI IS210:FG260
23601	LIQUID DEFLECTOR	370	NATURAL RUB ASTM2000AA-70SHORE/7MPa
24000	BEARING HOUSING	012	CI IS 210-FG 260
25100	SUPPORT FOOT	042	MS IS:5986-Fe410WA (OLD-IS:1079)
26300*	ANGULAR CONTACT BEARING	000	STEEL
26400*	CYLINDRICAL ROLLER BEARING	000	STEEL
27000	BEARING COVER DE	012	CI IS 210-FG 260
27100	BEARING COVER NDE	012	CI IS 210-FG 260
31100*	SHAFT SLEEVE	556	ST ST ASTM A276-410(300BHN)-ANLD
32000*	KEY FOR IMPELLER	053	CS IS1570:40C8 HOT RLD
32100	KEY FOR COUPLING	053	CS IS1570:40C8 HOT RLD
33000	IMPELLER NUT	253	ST ST ASTM A276-410 ANLD
33600*	BEARING LOCK NUT	052	CS IS1570:20C8 HOT RLD
35000*	STUFFING BOX BUSH	012	CI IS 210-FG 260
41500*	LOCK WASHER -BRG.LOCK NUT	050	CS IS1570:10C4 HOT RLD
43000*	GLAND PACKING	810	PTFE BRAIDED WITH GRAPHITE (PTFE-NONAS)
44100	GREASE NIPPLE	444	CS IS:1367 Part3 CL4.6 CDP
47900*	HELICOIL SCREW LOCK INSERT	250	ST ST ASTM A276-304 ANLD
48500*	INTERNAL CIRCLIP	054	SPRING ST IS:4072-80C6
50200*	FELT RING -DE SIDE	375	FELT
50201*	FELT RING -NDE SIDE	375	FELT
51100*	GASKET : CASING COVER	702	NON ASBESTOS FERROLITE NAM37 OR EQ
51400*	GASKET : BEARING COVER	702	NON ASBESTOS FERROLITE NAM37 OR EQ
51500*	GASKET : SH. SLEEVE & IMP.	702	NON ASBESTOS FERROLITE NAM37 OR EQ
68200*	GASKET : IMP. & IMP. NUT	702	NON ASBESTOS FERROLITE NAM37 OR EQ

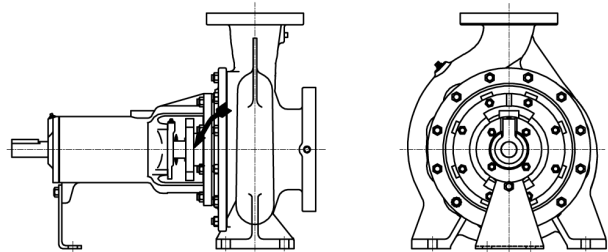

STUFFING BOX SEALING: SELF INTERNAL

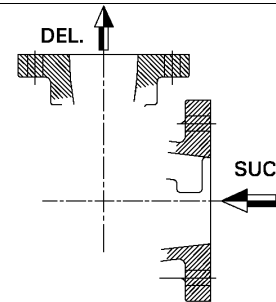

PUMP FLANGES (FF)

- NOTES:**
- * * * INDICATES RECOMMENDED SPARES.
 - FASTENERS IN LIQUID CONTACT ARE IN CS

IMPORTANT: THIS DRAWING IS THE PROPERTY OF Kirloskar Brothers Limited. AND MUST NOT BE USED OR COPIED WITHOUT THEIR PRIOR AUTHORITY IN WRITING.

PUMP	CPHM 65/32_2900RPM	MOC	01
ENQUIRY NO./DATE	/	QUANTITY	1
PO. NO./DATE	-	TAG NO.	001
QUOTATION NO.	0	DATE.	-
O/A. NO.	-	MISI.	-
CUSTOMER	-		
END USER	-		
PROJECT	Default		
CONSULTANT	-		
SERVICE	-		

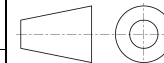

Kirloskar Brothers Limited
KIRLOSKARVADI - 416308, DIST.- SANGLI (INDIA)

CROSS SECTIONAL DRAWING

DRAWING NO. **TC78-1**

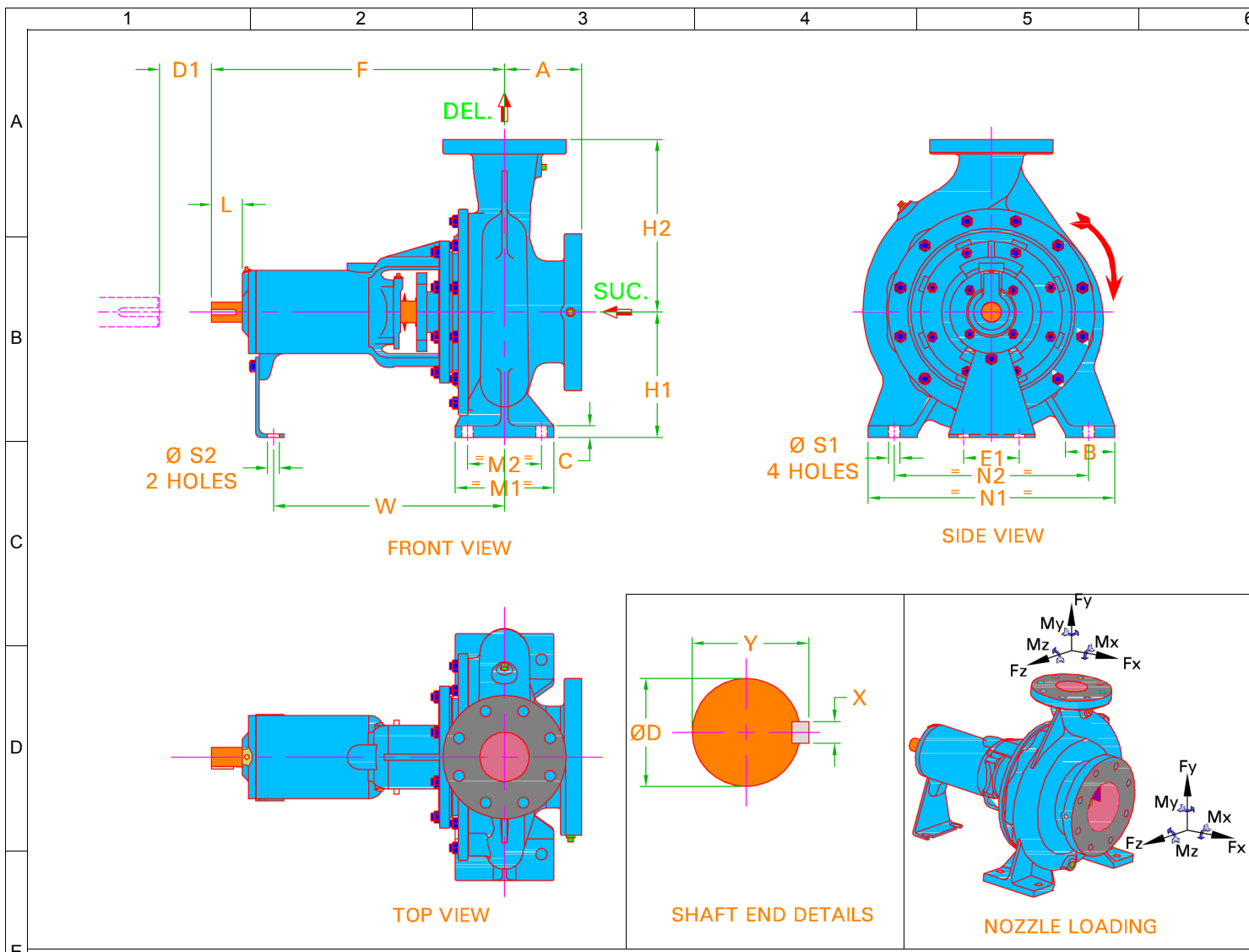

PUMP DUTIES			
CAPACITY	90.00 m3/h	EFFICIENCY	59.43 %
TOTAL HEAD	108.0 m	PUMP INPUT	44.48 kW
DENSITY	0.998 kg/dm3	NPSHR	3.52 m

FLANGE DRILLING STANDARD AND DETAILS					
SUCTION	BS EN1092 PN16 FF		DELIVERY	BS EN1092 PN16	
	NOM. SIZE	RF DIA.	P.C.D.	NO OF HOLES	HOLE DIA.
SUCTION	100 mm	N.A.	180 mm	8	18.0
DELIVERY	65.00 mm	N.A.	145 mm	4	18.0

ALLOWABLE NOZZLE LOADING						
	FORCES			MOMENTS		
	Fx	Fy	Fz	Mx	My	Mz
SUCTION	170.0 kgf	210.0 kgf	135.0 kgf	883 N.m	490 N.m	392 N.m
DELIVERY	170.0 kgf	210.0 kgf	135.0 kgf	883 N.m	490 N.m	392 N.m

TAPPING DETAILS	
DESCRIPTION	SIZE / TYPE
Suction Gauge	1/2"BSP
Delivery Gauge	1/2"BSP
Casing Drain	1/2"BSP
Casing Vent	NA
Bearing Cooling in / out	NA
Pad Cooling in / out	NA
Priming in	NA
Base Drain	1 BSP



DIRECTION OF ROTATION FROM DE: CLOCKWISE

PUMP	CPHM 65/32_2900R	PUMP WT.	114.0
REC. DRIVER RATING	55KW	RATED SPEED	2965R
ENQ. NO./DATE	/	QUANTITY	1
PO. NO./DATE	-	TAG NO.	001
QUOTATION NO.	0	DATE	-
O/A NO.	-	MISI	-
CUSTOMER	-		
END USER	-		
PROJECT	Default		
CONSULTANT	-		
SERVICE	-		

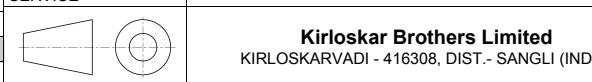

Kirloskar Brothers Limited
KIRLOSKARVADI - 416308, DIST. - SANGLI (INDIA)

PUMP OUTLINE DRAWING

NOTES:
 • ALL DIMENSIONS ARE IN mm
 • DIM 'D1' INDICATES THE DISTANCE REQUIRED TO REMOVE BACK PULL OUT ASSEMBLY.

IMPORTANT: THIS DRAWING IS THE PROPERTY OF Kirloskar Brothers Limited AND MUST NOT BE USED OR COPIED WITHOUT THEIR AUTHORITY IN WRITING.

A	F	H1	H2	B	C	M1	M2	N1	N2	S1	E1	S2	W	-	D
125	530	225	280	80.00	16.00	160	120	400	315	18.00	110	15.00	370	-	42.00
X	Y	L	D1	-	-	-	-	-	-	-	-	-	-	-	-
12.00	45.00	110	140	-	-	-	-	-	-	-	-	-	-	-	-
-	-	-	-	-	-	-	-	-	-	-	-	-	-	-	-
-	-	-	-	-	-	-	-	-	-	-	-	-	-	-	-

DRAWING NO. TL78-1-